

Rogers Axle & Spring Works Pty. Ltd.

ABN 70 102 005 318

3 Antimony Street, Carole Park Q 4300 P.O.Box 91 Mount Crosby 4306

Phone: (07) 3271 1744 Fax: (07) 3271 1156

INSTALLATION & MAINTENANCE GUIDE

75 series tandem & tri axle suspensions comprise equaliser rockers fitted with large polyurethane bushes. The bushes rely on the shear strength of the polyurethane for operation. Hence, the rocker bolt & nut **MUST** be tightened fully with the rocker set in the horizontal position (recommended 395-410Nm (290-300ft.lbs.)).

For other suspension systems, rocker pivot & shackle bolts fitted with 'Nyloc' type nuts must be tightened firmly allowing for rotational movement of bushed components.

All suspensions are supplied with the axle saddles supplied loose for fitment between the axle & springs.

The axle saddles comprise a piece of flat rectangular steel with a single hole in the centre.

Once the suspension is fitted to the trailer chassis, rest the axle/s on top of the springs and place the axle saddles between the axle and springs, with the hole over the spring centre bolt.

Fit the u-bolts and nip-up the u-bolt nuts such that the axle is held firmly in position, though being able to be moved with the tap of a hammer. Ensure flat washers are fitted between plate & nuts.

For overslung suspension (axle underneath the spring) arrangements ensure that the spring centre bolt is fitted with the bolt head to the underside of the spring. Hold the axle loosely in position under the springs with the u-bolt assemblies. Place the axle saddles in gap between the axle & springs with the axle saddle hole placed over the spring centre bolt. Nip-up the u-bolts as above. Please note that overslung configurations reduce the capacity of the spring and an extra leaf may need to be added to the spring pack.

Align the axle perpendicular and equispaced either side of the chassis centre by tapping in place with a hammer.

Once aligned, weld the axle saddles longitudinally both sides with full penetration 10mm fillet welds using low hydrogen electrodes or automatic welding processes. This process is necessary to prevent the axle assembly from rotating as a result of applied brake torque. Hence, good quality welds produced by sound welding practices are essential.

Tighten the u-bolts to the correct torque (recommended 105Nm (77ft.lbs.) for 16mm & 205Nm (150ft.lbs.) for 20mm u-bolts).

The brake actuator/springbrake rods must be trimmed on assembly such to ensure that at mid stroke with the yoke fitted to the appropriate slack adjuster position, the rod is perpendicular to the slack adjuster arm.

Ensure that the emergency release tool is fitted to the springbrakes and that the spring is wound back prior to trimming the rod length, otherwise the rod may be too short. Refer to page 2 for further details.

A spanner (3/4 AF?) must be located in an inconspicuous position forward of the leading axle to suit the springbrake emergency release tool nut. A combination ring/open end spanner attached to the inside chassis member via a bolt & wing nut to the ring end will suffice.

SPRINGBRAKE & BOOSTER INSTALLATION

To install springbrakes correctly remove springbrake tool as shown in figure 1.

Remove dust plug(if fitted) from bottom of springbrake to reveal T slot as per figure 2.

Insert springbrake tool into rear of springbrake and rotate at 90° so tool cannot be pulled out. Replace washer and nut onto springbrake tool and tighten until the nut can be tightened no more as per figure 3. Trim the springbrake rod to length to ensure when at mid stroke with the clevis fitted the springbrake rod is perpendicular to the slack adjuster as per Figure 4. Once rod is cut undo and remove springbrake tool from the rear of the springbrake and replace to original position.

When installing the air booster cut the rod as per above. No springbrake tool is required for or fitted to boosters.

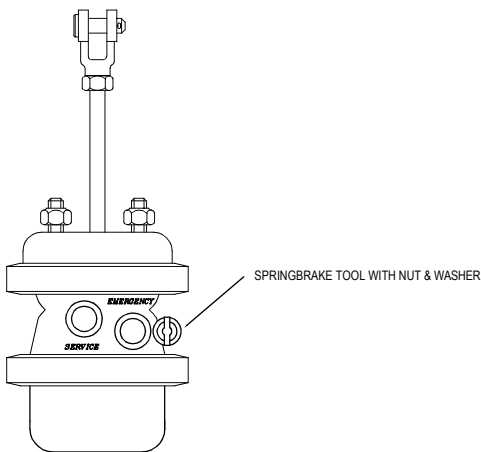

FIGURE 1

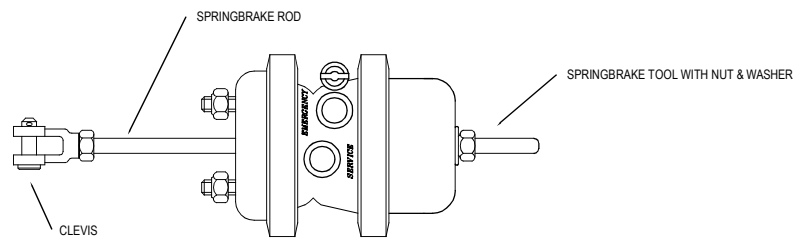

FIGURE 3

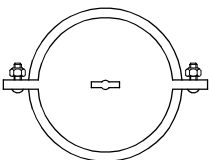

FIGURE 2

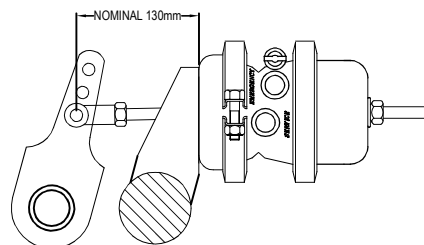

FIGURE 4

PERIODIC INSPECTION, MAINTENANCE & REPAIR

SAFETY FIRST

To ensure safe operation and optimum component life, the following is recommended:

- Match all running gear components: i.e axles, wheels, tyres, brakes & suspensions must ALL be rated for the specified load.
- Do not overload axle assemblies, wheels or tyres.
- Ensure wheel nut taper and wheel nut countersink match. Incorrect wheel nut seating may result in wheel failure or broken axle components.
- Wheel Nuts must be tightened to correct torque (recommended 147Nm (108ft.lbs.) for ½” UNF wheel studs and recommended 395-410Nm (290-300ft.lbs.) for 7/8” BSF wheel studs).
- Wheel nut torque to be checked after the first 160km of operation, re-checked after 3000km or 3 months (whichever occurs first) then periodically thereafter every 10000km or 6 months, whichever occurs first.
- Care must be taken to ensure equal side to side loading of axle assemblies.
- It is recommended that maximum speed & payload, correct tyre inflation pressure, wheel nut torque & bearing maintenance information be displayed along with other safety information in a conspicuous place on the completed trailer.

BEARINGS

Proper maintenance of tapered roller bearings result in optimum bearing life. Bearings should be removed & repacked in grease every 6 months or 10,000 km whichever occurs first.

BEARING REMOVAL

- Remove wheel & tyre.
- Remove grease cap & split pin.
- Loosen adjusting nut and remove from axle.
- Pull the hub assembly and remove it from the axle spindle.
- Knock out inner bearing cone & grease seal.

BEARING INSPECTION

- Inspect existing grease for dust & grime. If dust is evident, the seal must be replaced.
- Clean existing grease from bearing.
- Inspect bearings for wear and cup scouring. Ensure roller cage on bearing cone is intact. Replace bearing if necessary.

NOTE: When replacing bearings, replace both cup & cone.

BEARING LUBRICATION

Pack bearing cones with grease and install into wheel hub. Inner bearing cone is held in place with grease seal.

Repack bearings with grease every 6 months or 10,000 km whichever occurs first.

RECOMMENDED GREASE FUCHS 'RENOLIT LX2' or equivalent.

ADJUSTMENT

- Ensure the washer is fitted between the adjusting nut and the outer bearing cone.
- Tighten the adjusting nut while rotating the wheel hub in the opposite direction to the nut rotation until there is a slight bind (approx. 170 Nm (125ft.lbs.) torque) to be sure that all bearing surfaces are in contact.
- Then, back off the adjusting nut 1/16 to 1/4 turn to the nearest locking slot or sufficiently to allow the hub to rotate freely within the limits on .025mm (0.001) to .25mm (.010) end play.
- Lock adjusting nut into position with new split pin.

WARNING: Failure to back off adjusting nut will cause bearings to run hot and be damaged. Wheel may lock or come off during operation.

WHEEL NUTS

Wheel nuts play an important role in the safety of any vehicle, as they secure the wheel in position. For wheel nuts to function properly; the taper on the nut must match the countersink in the wheel, the taper on both the nut and wheel must not be damaged, and the seating force of the nut must be sufficient to hold the nut in place.

Inspect wheel nut taper and wheel countersink for damage every 10000km or 12 months, whichever occurs first. If wheel mounting holes become elongated, this may be the result of mismatched wheel & nut tapers and/or incorrect wheel nut torque.

BRAKES

- Ensure all brake components are in good repair at all times. Brake performance relies upon proper lining material and thickness. Hence, use only genuine replacement parts.
- Trailer-master 'S' cam foundation brakes comprise fixed upper pivots with removable roller type cam followers. Worm type camshaft slack adjusters are fitted to air operated actuators.
- Failure to maintain brake components and adjustment may result in loss of brake efficiency and possible dislodgment of roller cam followers.
- Check brake shoes/linings & drums for wear or damage every 10,000 km or 6 months which ever occurs first.
- Replace worn or damaged components if necessary.

Adjustment Procedure: (Must be performed on flat, level ground)

- If adjusting brakes with springbrakes fitted, insert the springbrake release tool, washer & nut (as per page 2 of this manual) and wind back the spring to release the park brakes.
WARNING: Only release park brakes from one wheel at a time.
- Raise wheel that is to have brake adjusted, off the ground.
- Use 9/16" spanner, depress locking collar and rotate adjuster screw on slack adjuster so that the rod inside the booster is wound in until the wheel can no longer rotate.
- Back off adjuster screw on the slack adjuster until wheel rotates freely (approx. ¼ turn).
- Lower wheel back to the ground. For brakes fitted with springbrakes, remove release tool from the back of the springbrake 'T' slot to apply park brake and secure release tool in place on springbrake housing.
- Repeat procedure to all remaining unadjusted wheels.

SUSPENSION

To ensure trailer stability and safety, regular maintenance of suspension components is essential

- Check spring eye and rocker (if fitted) bushes and pins for wear or damage every 5000 km or 6 months which ever occurs first.

Failure to maintain suspension bushes and shackle pins will result in elongation of spring hanger mounting holes resulting in premature/increased maintenance costs.

- U-bolts must be checked for tightness after the first 1000km of operation and periodically thereafter every 5000km or 6 months whichever occurs first.

LOOSE U-BOLTS MAY RESULT IN BROKEN SPRING LEAVES.